

SN
Steel Screw Gears



m1 ~ 4 Page 496



SUN
Stainless Steel Screw Gears



Newly added

m1 ~ 3 Page 500



AN
Aluminum-Bronze Screw Gears



m1 ~ 4 Page 502



PN
Plastic Screw Gears

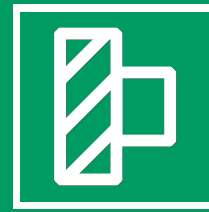

m1.5 ~ 3 Page 504

Screw Gears

Spur Gears

Helical Gears

Internal Gears

Racks

CP Racks & Pinions

Miter Gears

Bevel Gears

Screw Gears

Worm Gear Pair

Bevel Gearboxes

Other Products

Catalog Number of KHK Stock Gears

The Catalog Number for KHK stock gears is based on the simple formula listed below. Please order KHK gears by specifying the Catalog Numbers.

(Example) Screw Gears

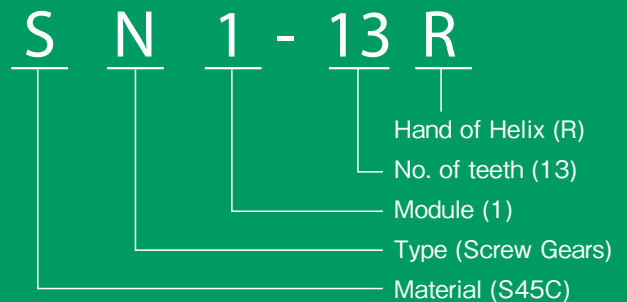

Material	Type
S S45C	N Screw Gears
SU SUS303	
A CAC702	
P MC901	

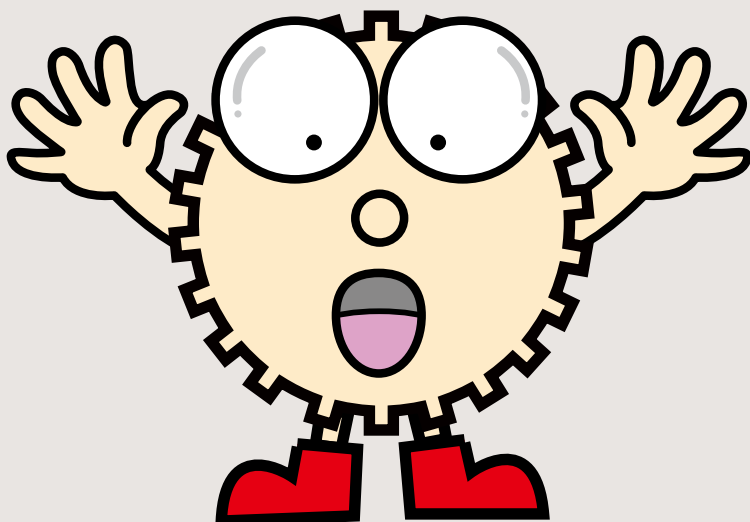

Feature Icons

RoHS Compliant Product	Stainless Product
Re-machinable Product	Resin Product
Finished Product	Copper Alloy Product
Heat Treated Product	Injection Molded Product
Ground Gear	Black Oxide coated Product



Characteristics



KHK stock screw gears come in four materials, S45C, SUS303, CAC702 (formerly A BC2) and MC nylon, in modules 1 ~ 4 and numbers of teeth from 10 to 30.

Catalog No.	Module	Material	Heat Treatment	Tooth Surface Finish	Precision JIS B 1702-1:1998	Secondary Operations	Features
SN	1 ~ 4	S45C	—	Cut	N9	○	Popular screw gears. Additionally, gear tooth induction hardening secondary operations can be performed.
SUN	1 ~ 3	SUS303	—	Cut	N9	○	Suitable for food machinery due to SUS303's rust resistant qualities.
AN	1 ~ 4	CAC702 (A BC2)	—	Cut	N9	○	Aluminum bronze made products and have excellent wear resistance.
PN	1.5 ~ 3	MC901	—	Cut	N9	○	Light-weight products made of MC Nylon and can be used without lubrication.

○ Possible △ Partly possible × Not possible

Selection Hints



Please select the most suitable products by carefully considering the characteristics of items and contents of the product tables. It is also important to read all applicable "CAUTION" notes shown below before the final selection. Since screw gears come in right- or left-hand helix, make sure to include the letter "R" or "L" in the catalog number when you order.

1. Caution in Selecting the Mating Gears

Screw gears are used for offset shafts. Whether the shafts are paralleled offset or skewed offset depends on the helix hands of the mating gears.

Direction of shaft	Arrangement of helix hands
Skewed shafts	RH-RH or LH-LH
Parallel shafts	RH-LH

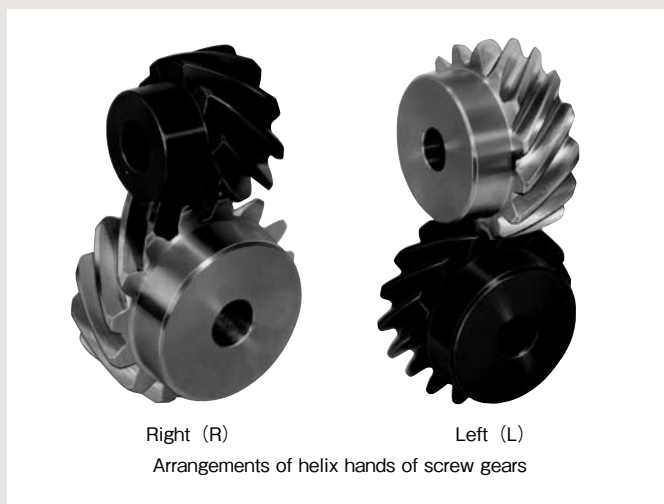

Trusted quality achieved by years of experience.

Efficient production by lapping cutting processes.



Gear cutting by a Hobbing Machine

Application Example

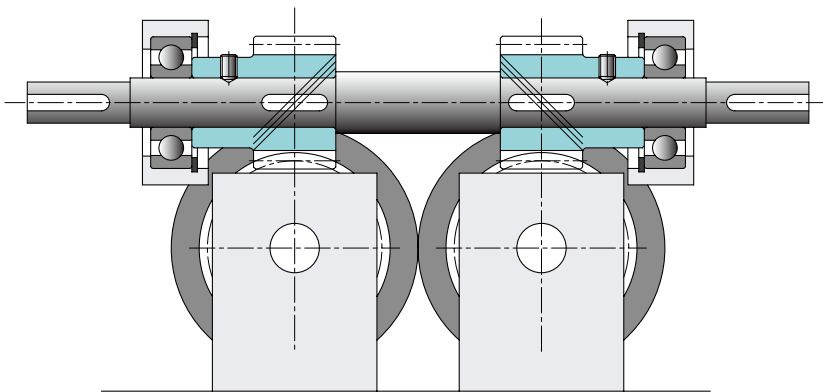

Feed by rollers * (It rotates 2 rollers by one input shaft.)

* The illustration above is a design example, not a design for machinery or a device in actual use.

Application Hints



2. Caution in Selecting Gears Based on Gear Strength

The allowable surface strength listed in the product pages were derived using the Niemann formula as reference values (for the case of skewed offset shafts).

There is paucity of data on the strength of screw gears. The values of constant K_0 used in the calculations, which depend on the material of the mating gears, are our estimates. The mathematic expression below shows the Niemann formula to determine allowable tangential force F_t (kgf) and allowable torque T (kgf, m) on a basic circle.

$$F_t = 1.43d_1^2 f_z K_s$$

$$T = \frac{F_t d_1}{2000}$$

Where

d_1 : standard pitch diameter of pinion (mm)

f_z : coefficient based on no. of teeth combination

K_s : coefficient based on materials and sliding

$$K_s = K_0 \frac{2}{2 + V_s}$$

Where

K_0 : coefficient based on material selection

V_s : sliding speed (m/s)

$$V_s = \frac{\pi n d_1}{60000 \cos \beta}$$

Where

n : rotation (rpm)

β : helix angle (45°)

Value of f_z

$Z_2 \backslash Z_1$	10	13	15	20	26	30
10	1.538					
13	2.005	1.538				
15	2.279	1.786	1.538			
20	2.963	2.329	2.053	1.538		
26	3.695	2.963	2.588	2.005	1.538	
30	4.161	3.350	2.963	2.279	1.786	1.538

K_0 values depending on material combination

Catalog No.	Mating gear	K_0	The maximum allowable sliding speed m/s	No. of teeth of mating gears	Rotation
SN	SN	0.0030	2.5	Same no. of teeth	100rpm
SUN	SN	0.0030 <small>Note 1</small>	2.5 <small>Note 1</small>		
AN	SN	0.0050	5		
PN	SN	0.0030 <small>Note 1</small> (0.0021)	2.5 <small>Note 1</small> (1.0)		

(NOTE 1) K_0 values and the maximum allowable sliding speed of SUN PN products are set by KHK. Screw gears are basically used with lubrication. In case of using PN products without lubrication, the parenthetical values shown in the table are applied.

In order to use KHK stock screw gears safely, read the Application Hints carefully before proceeding. Also, please refer to the "Application Hints" in the technical information section on KHK stock spur gears (Page 36) when performing secondary operations.

1. Points of Caution in Assembling

- ① KHK stock screw gears are designed to give the proper backlash when assembled using the center distance given by the formula below with a tolerance of H7 to H8. The amount of backlash is given in the product table for each gear.

$$a = \frac{d_1 + d_2}{2}$$

Where

a : Center distance

d_1 : Pitch diameter of pinion

d_2 : Pitch diameter of gear

- ② Overall length tolerance of Screw Gears

Total Length (mm)	Tolerance
up to 30	0 - 0.10
30 up to 100	0 - 0.15

(CAUTION) PN Plastic Screw Gears are excluded.

- ③ Due to the helix of screw gears, they produce axial thrust forces. The bearings must be selected properly to be able to handle these thrust forces. The directions of thrust change with the hand of helix and the direction of rotation as illustrated below.

Direction of rotation and thrust force

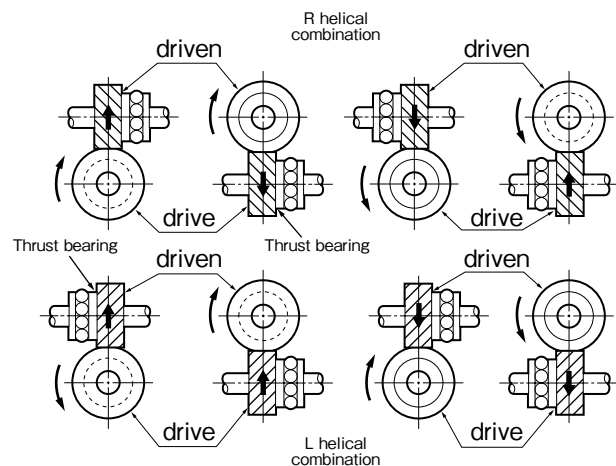

(CAUTION) For parallel shaft applications, see the Application Hints for KHK Helical Gears. (Page 351).