



Spur Gears  
Helical Gears  
Internal Gears  
Racks  
CP Racks & Pinions  
Miter Gears  
Bevel Gears  
Screw Gears  
Worm Gear Pair  
Bevel Gearboxes  
Other Products

## Selection Guide

### Essential data for selection

Load torque, type of prime mover, input speed, speed ratio, running time, coupling method, and frequency of start and stop.

### Selection Procedure

The performance table in the catalog is based on the design conditions that the prime mover is a motor, the load is uniform, and the unit runs 10 hours per day.

- a) When using the units under any other condition, it is necessary to correct the value of load to torque by applying the service factors shown in Table 1.

**Corrected Load Torque = Load torque applied to gearbox x Service factor <See Table 1>.**

Service factors (Sf) (Table 1)

Loading condition	Service factors (Sf)		
	Less than 3 hrs/day operation	3-10 hrs/day operation	More than 10 hrs/day operation
Uniform load	1 (1)	1 (1.25)	1.25 (1.50)
Light impact load	1 (1.25)	1.25 (1.50)	1.50 (1.75)
Heavy impact load	1.25 (1.50)	1.50 (1.75)	1.75 (2.00)

(NOTE) 1. Use the factors in parentheses when frequency of starts and stops exceed 10 times per hour.  
 2. Also, use the factors in parentheses when a prime mover other than a motor is used (for example, an internal combustion engine).

Keep the corrected load torque at the speed at less than the allowed X & Y axis torque (Speed ratio 1:1), or the allowable Y axis torque (Speed ratio 1:2) shown in the performance table.

- b) Select an appropriate shaft layout from the shaft layout drawing for each model.
- c) Check for overhang load space (O.H.L.)  
 Overhang load is a load applied beyond the bearing support. Examining the overhang load is indispensable whenever chains, belts, or gears are used to couple the unit with the mating machinery.

$$O.H.L. = \frac{T_{LE} \times K_1 \times K_2}{R} \text{ (N) [kgf]}$$

$T_{LE}$  : Corrected load torque applied to the gearbox shaft (N · m) [kgf · m]  
 $R$  : Pitch radius of sprocket, pulley, gear, etc., mounted on the gearbox shaft (m)  
 $K_1$  : Factor depending on the method of coupling <See Table 2>  
 $K_2$  : Factor depending on the position of load <See Table 3>

\* The value of O.H.L. from the equation above must be smaller than the value of allowable O.H.L. on the X-and the Y-axis shown on the performance table.

Factor  $K_1$  (Table 2)

Coupling method	$K_1$
Chain, timing belt	1.00
Gear	1.25
V belt	1.50

Factor  $K_2$  (Table 3)

Position of load	$K_2$
Near the support	0.75
Middle of shaft	1.00
End of the shaft	1.50

### Position of load

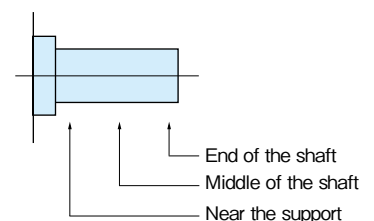

- d) Select a model capable to satisfy all of a), b) and c) obtained above.

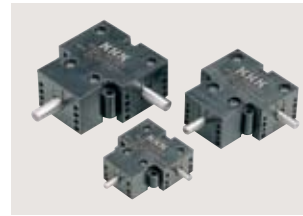

PBX-L Type

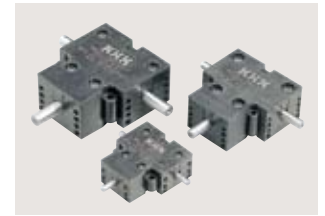

PBX-T Type



KBX-L Type



KBX-T Type

■ Selection Examples

Example 1

- Application / Conveyor (uniform load)
- Load torque / 78.4N · m {8kgf · m}
- X-axis rotational speed / 300rpm
- Speed Ratio / 1 : 2
- Shaft layout / As illustrated at right
- Running time / 12 hours/day
- Coupling method / X-axis – Coupling  
Y-axis – Chain (positioned at the middle of the shaft)
- Installation / Horizontal
- Location / Indoors

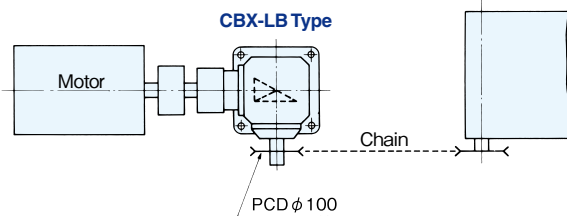
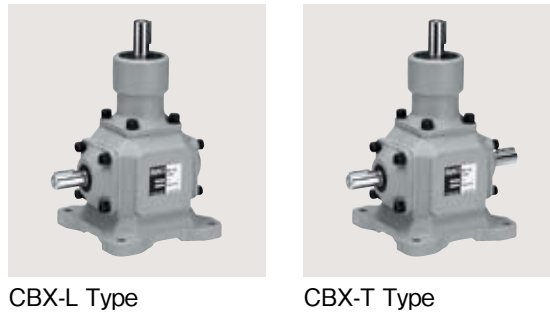

① Torque Analysis

Service factor under load is  $S_f = 1.25$  (Table 1).  
Accordingly, corrected load torque applied to Y-axis.  
 $T_{LE} = 78.4 \times 1.25 = 98N \cdot m$  { $T_{LE} = 8 \times 1.25 = 10kgf \cdot m$ }

② O.H.L. Analysis

O.H.L.on the Y-axis

$$O.H.L. = \frac{T_{LE} \times K_1 \times K_2}{R} = \frac{98 \times 1 \times 1}{2 \times 1000} = 1960N \quad \{ O.H.L. = \frac{T_{LE} \times K_1 \times K_2}{R} = \frac{10 \times 1 \times 1}{2 \times 1000} = 200kgf \}$$

③ Model Selection

A model capable of satisfying all of the design conditions, torque and O.H.L. is **CBX-322LB**.

Example 2

- Application / Line shaft drive
- Load torque / 58.8N · m {6kgf · m} (uniform load) for each A,B and C
- Rotational speed / 600rpm
- Speed Ratio / 1 : 1
- Shaft layout / As illustrated at right
- Running time / 8 hours/day
- Coupling method / All couplings
- Installation / Horizontal
- Location / Indoors

In case of an inline shaft drive, load applied to the Y-axis varies with the location of the gearbox. Therefore, an adequate model must be selected individually for each position. Service factor (Table 1) under the design condition is  $S_f=1.0$  for all gearboxes.

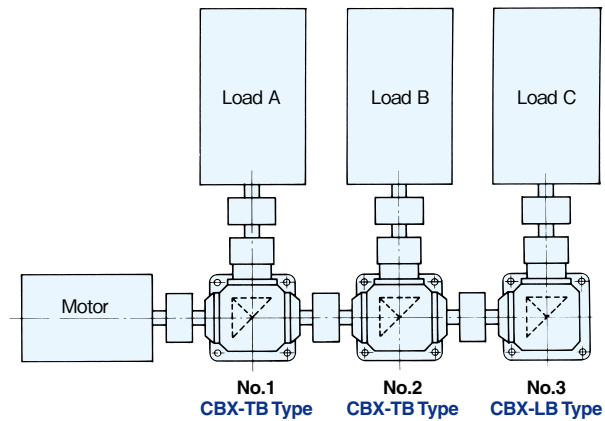

① Gearbox No.1

Corrected load torque applied to the X-axis that drives only load A is:  
 $58.8 \times 1.0 = 58.8N \cdot m$  { $6 \times 1.0 = 6kgf \cdot m$ }  
Corrected load torque applied to the Y-axis that drives load A, B and C is:  
 $(58.8 + 58.8 + 58.8) \times 1.0 = 176.4N \cdot m$   
{ $(6 + 6 + 6) \times 1.0 = 18kgf \cdot m$ }  
**CBX-401TB** is selected from the performance table.

② Gearbox No.2

Corrected load torque applied to the X-axis that drives only load B is:  
 $58.8 \times 1.0 = 58.8N \cdot m$  { $6 \times 1.0 = 6kgf \cdot m$ }  
Corrected load torque applied to the Y-axis that drives load B and C is:  
 $(58.8 + 58.8) \times 1.0 = 117.6N \cdot m$   
{ $(6 + 6) \times 1.0 = 12kgf \cdot m$ }  
**CBX-321TB** is selected from the performance table.

③ Gearbox No.3

Corrected load torque applied to the X-axis that drives only load C is:  
 $58.8 \times 1.0 = 58.8N \cdot m$  { $6 \times 1.0 = 6kgf \cdot m$ }  
Corrected load torque applied to the Y-axis that drives only load C is:  
 $58.8 \times 1.0 = 58.8N \cdot m$  { $6 \times 1.0 = 6kgf \cdot m$ }  
**CBX-251LB** is selected from the performance table.

④ Model selection

No.1 gearbox is **CBX-401TB**  
No.2 gearbox is **CBX-321TB**  
No.3 gearbox is **CBX-251LB**

- Spur Gears
- Helical Gears
- Internal Gears
- Racks
- CP Racks & Pinions
- Miter Gears
- Bevel Gears
- Screw Gears
- Worm Gear Pair
- Bevel Gearboxes
- Other Products



## ■ Moment of Inertia of KBX Bevel Gearbox's

Unit :  $\text{kg} \cdot \text{m}^2$

Type	Catalog No.	Pinion Shaft (X-axis)	Gear Shaft (Y-axis)
L	KBX-101L	$4.45 \times 10^{-6}$	$4.45 \times 10^{-6}$
	KBX-102L	$2.16 \times 10^{-6}$	$8.65 \times 10^{-6}$
	KBX-151L	$5.30 \times 10^{-5}$	$5.30 \times 10^{-5}$
	KBX-152L	$3.65 \times 10^{-5}$	$1.47 \times 10^{-4}$
	KBX-201L	$1.79 \times 10^{-4}$	$1.79 \times 10^{-4}$
	KBX-202L	$7.85 \times 10^{-5}$	$3.15 \times 10^{-4}$
T	KBX-101T	$4.75 \times 10^{-6}$	$4.75 \times 10^{-6}$
	KBX-102T	$2.23 \times 10^{-6}$	$8.93 \times 10^{-6}$
	KBX-151T	$5.60 \times 10^{-5}$	$5.60 \times 10^{-5}$
	KBX-152T	$3.37 \times 10^{-5}$	$1.50 \times 10^{-4}$
	KBX-201T	$1.94 \times 10^{-4}$	$1.94 \times 10^{-4}$
	KBX-202T	$8.20 \times 10^{-5}$	$3.28 \times 10^{-4}$

**[CAUTION]** The moments of inertia shown in this table are reference values. Please use data only for reference.

## ■ Moment of Inertia of CBX Bevel Gearbox's

Unit :  $\text{kg} \cdot \text{m}^2$

Type	Catalog No.	Pinion Shaft (X-axis)	Gear Shaft (Y-axis)
L	CBX-191L	$4.00 \times 10^{-4}$	$4.00 \times 10^{-4}$
	CBX-192L	$1.86 \times 10^{-4}$	$7.43 \times 10^{-4}$
	CBX-251L	$2.48 \times 10^{-3}$	$2.48 \times 10^{-3}$
	CBX-252L	$1.03 \times 10^{-3}$	$4.13 \times 10^{-3}$
	CBX-321L	$4.00 \times 10^{-3}$	$4.00 \times 10^{-3}$
	CBX-322L	$1.29 \times 10^{-3}$	$5.18 \times 10^{-3}$
	CBX-401L	$8.95 \times 10^{-3}$	$8.95 \times 10^{-3}$
	CBX-402L	$3.83 \times 10^{-3}$	$1.53 \times 10^{-2}$
T	CBX-191T	$4.05 \times 10^{-4}$	$4.05 \times 10^{-4}$
	CBX-192T	$1.87 \times 10^{-4}$	$7.48 \times 10^{-4}$
	CBX-251T	$2.50 \times 10^{-3}$	$2.50 \times 10^{-3}$
	CBX-252T	$1.04 \times 10^{-3}$	$4.15 \times 10^{-3}$
	CBX-321T	$4.08 \times 10^{-3}$	$4.08 \times 10^{-3}$
	CBX-322T	$1.31 \times 10^{-3}$	$5.25 \times 10^{-3}$
	CBX-401T	$9.20 \times 10^{-3}$	$9.20 \times 10^{-3}$
	CBX-402T	$3.88 \times 10^{-3}$	$1.55 \times 10^{-2}$

**[CAUTION]** The moments of inertia shown in this table are reference values. Please use data only for reference.

Spur Gears  
Helical Gears  
Internal Gears  
Racks  
CP Racks & Pinions  
Miter Gears  
Bevel Gears  
Screw Gears  
Worm Gear Pair  
Bevel Gearboxes  
Other Products